

A98 & SA98

A98 & SA98

MURPHY RADIO SERVICE INSTRUCTIONS

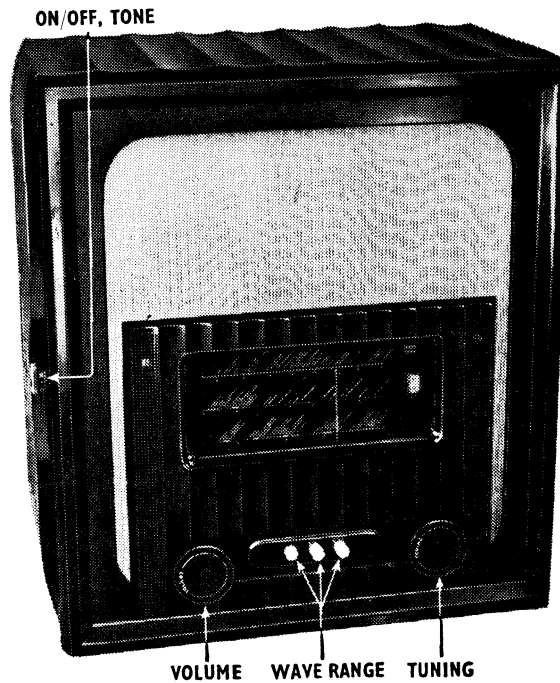

MAINS SUPPLY:	105 to 115 volts, 50 to 100 cycles. 200 to 250 volts, 50 to 100 cycles.
WAVE RANGES:	16.7 to 50 metres. 190 to 550 metres. 970 to 2000 metres.
INTERMEDIATE FREQUENCY:	465 Kc/s.
VALVES:	Mazda TH41, VP41, HL41DD, PEN45, UU6.
PILOT LAMP:	6.2 volt, 0.3 amp. M.E.S.
SPEECH COIL IMPEDANCE:	3 ohms.
TOTAL WEIGHT:	33 lb.
CONSUMPTION:	Approx. 70 watts on 230 volts.
CABINET DIMENSIONS:	9½" × 15¼" × 17"

Issued by

**MURPHY RADIO LTD · WELWYN GARDEN CITY
HERTS · ENGLAND**

TEL: WELWYN GARDEN 800

AERIAL FILTERS

In receivers operating close to transmitters, an aerial filter, as supplied by Murphy Radio, may be necessary if tuneable whistles occur on stations. The actual area affected is usually within a radius of three to four miles of the transmitter, though it may be modified by such local conditions as the nature of the country, the transmitter aerial power, and the type of receiving aerial in use. The object of the filter is to reduce the interfering signal to the receiver and it may be a single or double unit according to the number of local stations. It plugs into the sockets on the chassis deck just above the aerial socket, and it is essential that the brass link joining the sockets should be cut before fitting the filter.

In order to adjust the filter when fitted, remove the chassis from its cabinet and connect a 0-10 v. D.C. meter between the chassis and the cathode of V1 (Test point 19). Tune in the local transmitter on the receiver, when it will be seen that the meter reading will fall. After tuning carefully for minimum reading, adjust the coil core for maximum meter reading. If the filter is a double unit the same procedure must be followed for each section.

MECHANICAL DETAILS

DISMANTLING

The moulded escutcheon plate over the tuning scale and controls can be removed by unscrewing the four fixing screws after the tuning and volume control knobs have been removed. This gives access to the trimming screws for the R.F. and oscillator circuits. The chassis is secured by four fixing bolts in the base of the cabinet.

Although the leads to the tone control and loudspeaker are long enough to allow the chassis to be withdrawn, complete freedom of movement of the chassis can be achieved by unplugging the loudspeaker from the socket on the output transformer and releasing the tone control from the slotted bracket in the cabinet by unscrewing the fixing nuts. A temporary mounting for the tone control is provided underneath the chassis.

The chassis is made up of a front panel and a base, which can easily be separated for test purposes. Connecting points between the base and the front panel are indicated by short arrows on the underneath view of the chassis, and when the wires have been unsoldered at these points the base and front panel can be separated by removing the four fixing screws in the front.

There is a protective plate over the aerial coils which can be removed by taking out the fixing screws. In replacing the plate see that the spring wire which interlaces the coil adjusting screws is replaced.

In replacing faulty components, the system of

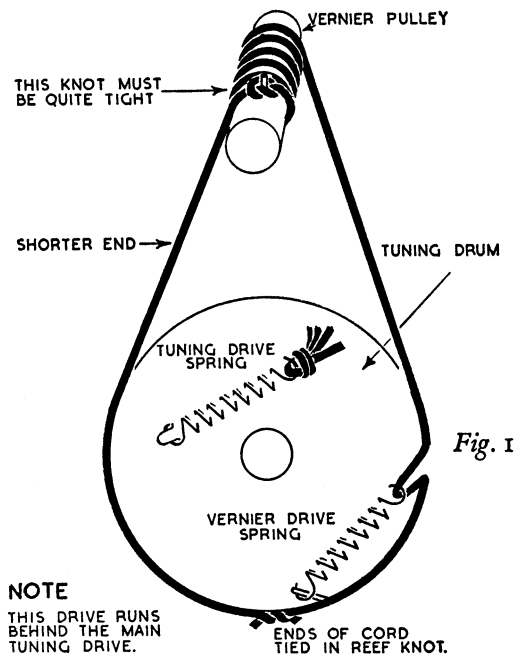

numbering employed in the circuit and layout drawings provides an almost complete guide for wiring, but, in the case of earthing wires, it is important that the correct earthing points should be used.

The screening for the V/C wires must be connected to the earthed end of the volume control.

The aerial section of the variable capacitor must be connected to the end tag of the R/C rack. The oscillator section is earthed to the top fixing screw for the capacitor assembly. The S.W. aerial coils are earthed at this point and also connected to the frame of the switch assembly. The M.W. and L.W. aerial

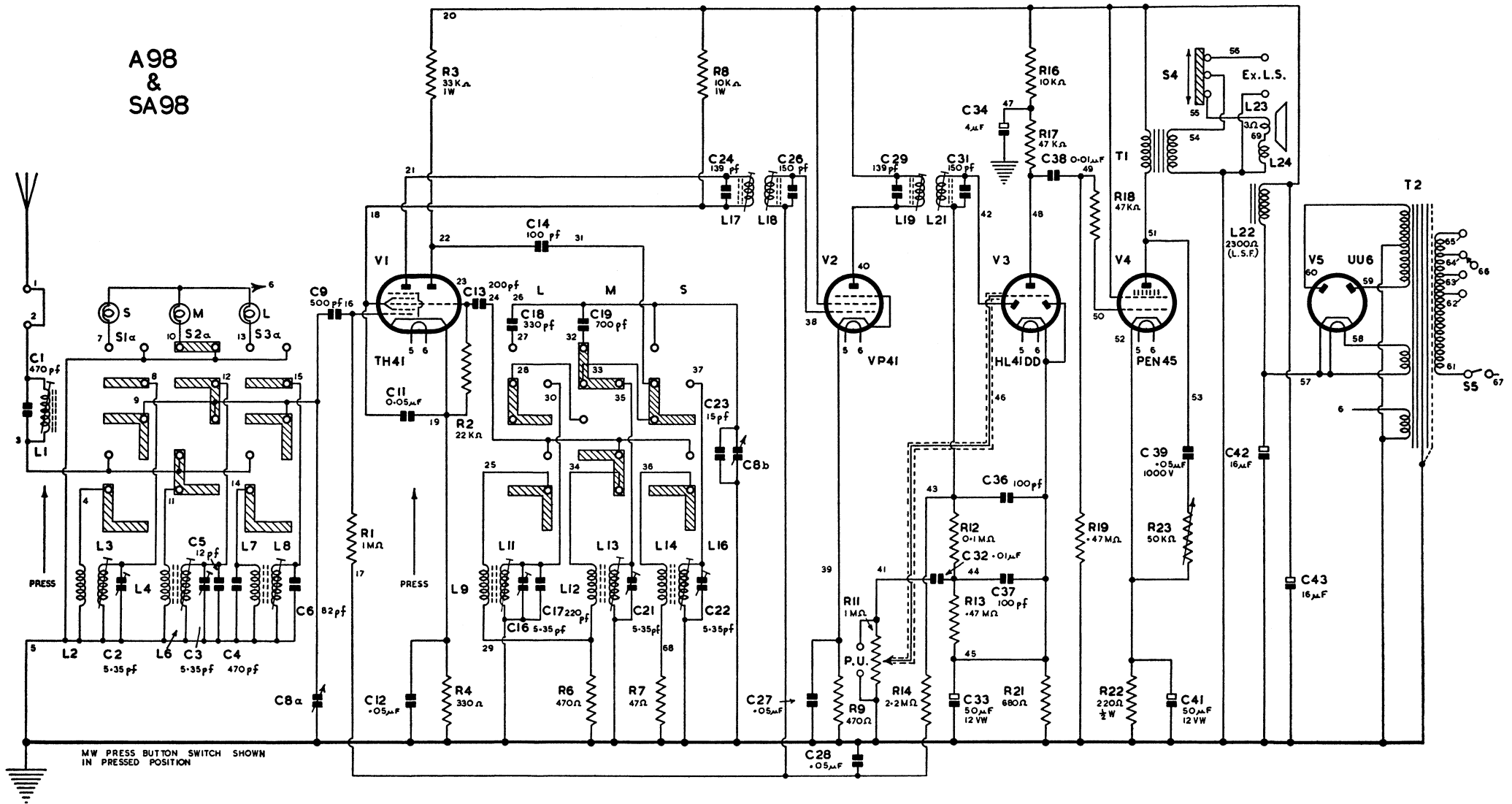
A98
&
SA98

RESISTANCE OF COILS

COILS	L1	L2	L6	L7	L8	L9	L11	L12	L13	L17-21	T1 Prim	T1 Sec	T2 Prim	H.T. Sec	T2 Screen
OHMS	3	0.6	1.2	24	13	1.0	2.4	0.9	1.6	6	300	0.15	6 + 10 + 2 + 3	160 + 165	2.5

anti-clockwise (capacitor vanes fully out of mesh). The procedure for fitting a new cord is as follows:

1. Take approximately 30 inches of light drive cord; tie a loose single knot in it about two thirds of the way from the end.

2. Set the tuning drive fully anti-clockwise (variable capacitor fully out of mesh).

3. With the shorter end of cord to the left and the longer end to the right (looking from the front of the chassis) fit the knot over the locating pin in

the vernier pulley and pull it tight (so that the cord is attached quite securely to the pin).

4. Pass the left-hand (shorter) end of the cord through the left-hand hole in the front panel, behind the main tuning drive cord and hold it against the tuning drum.

5. Wind the right-hand (longer) end of cord five times round the vernier pulley (clockwise, as viewed from the front with the turns behind the pin and running towards the back of the pulley) through the

right-hand hole in the front panel; then tie it to the other end of the cord in a reef knot so that it is held loosely around the drum. This operation is most easily carried out with the chassis front panel turned uppermost.

6. Cut off the surplus cord.

7. Pass the end of the tension spring through the hole in the drum (from the inside). Hook it on to the cord and ease the other end of the spring on to the fixing lug with the aid of a small screwdriver.

R																					
C						16			31		29 42,43 21 3				22 2		26				24
L								19	9 11 7 8		21		12 13 4 6		14 16		22	17 24		23	18
MISC	V4		T2 V5		V3							P.L.		V2							V1 T1

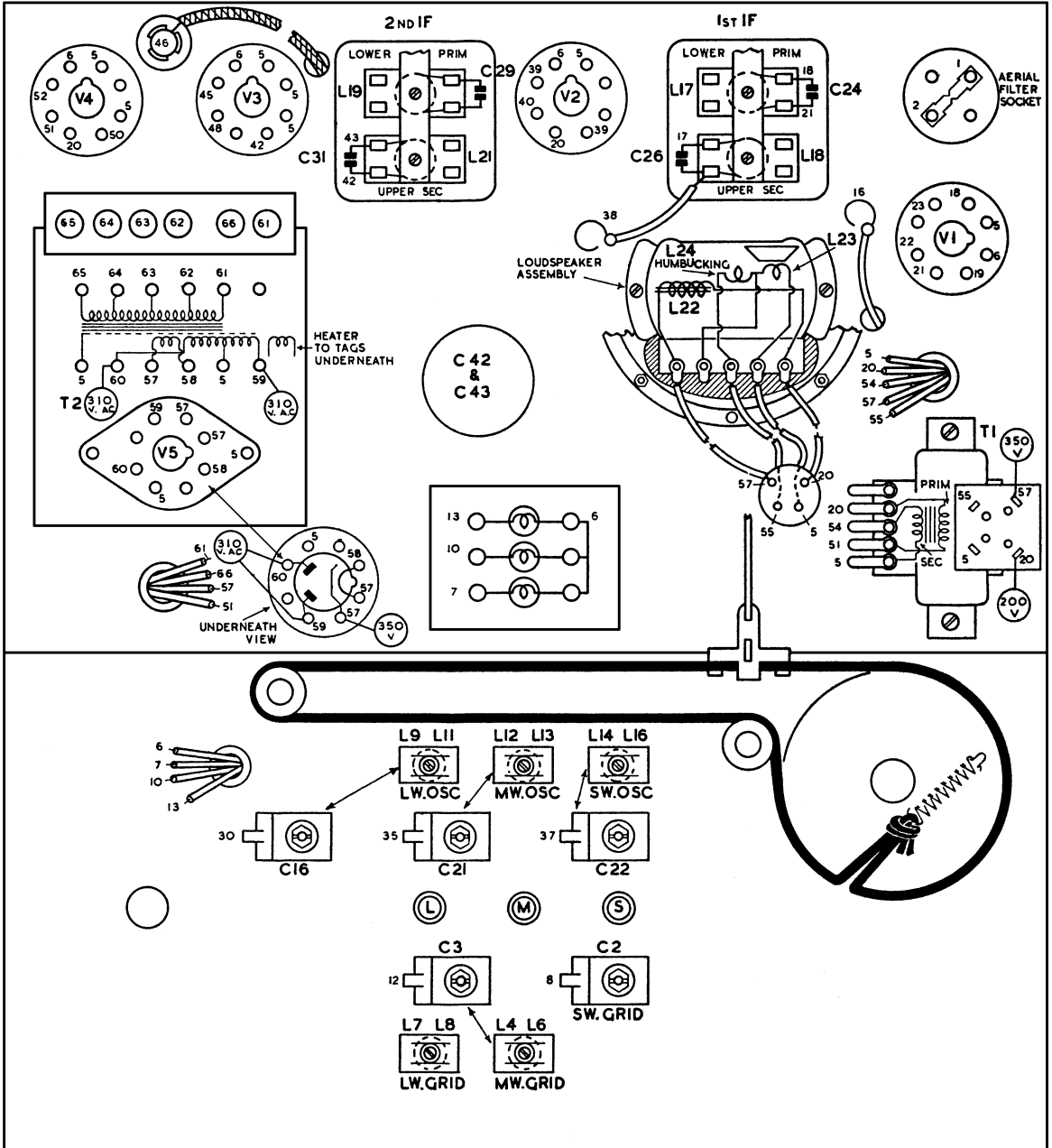

A98 & SA98 TOP VIEW.

R		23 22	19 18	11 17	21	12 13	14			6		9	7	8	1 3	4				2
C	39	41	38 34	33		37 36		6 17 18 28		42 43 32		4	27		5 19	9	12	23 13 14	8b 8a	11
L								19	8 9 21	7 11	6 12	4 13	14	16	2 3		18	17		
MISC		S5 V4		T2	V3					S3a S3b	S2a S2b			S1a S1b V2						V1

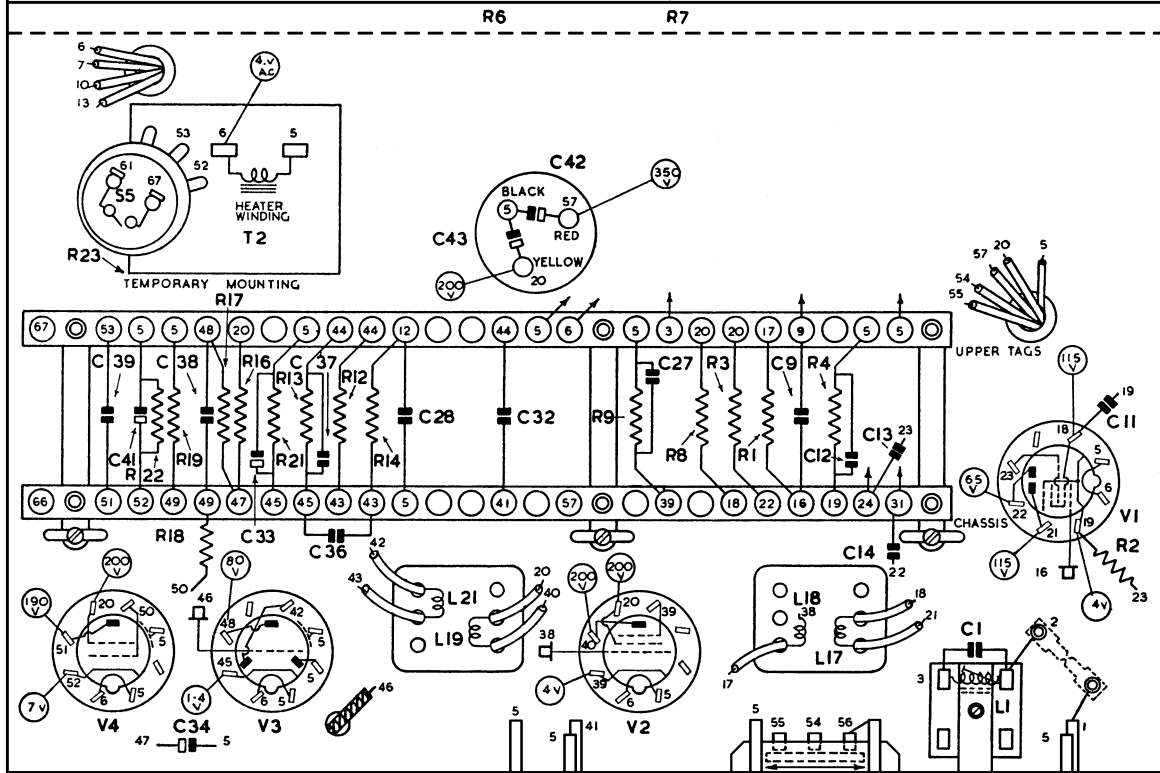
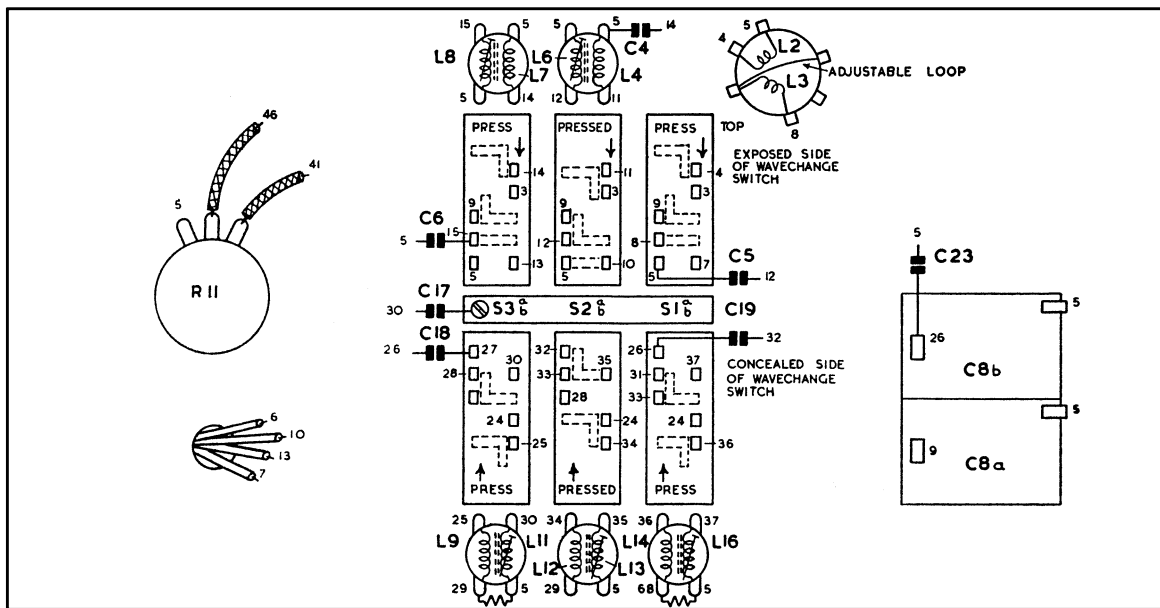

A98 & SA98 UNDERNEATH VIEW.

Voltages are average figures measured between test points and chassis, using a 1000 ohms-per-volt meter, with receiver switched to M.W. and working on 230 volt mains under no signal conditions.

TRIMMING

All adjustments are made for maximum reading on an output meter connected to Ext. L.S. sockets, with V/C at maximum and the Service Sig. Gen. output adjusted to produce the lowest convenient meter reading. Before starting R.F. adjustments, see that the tuning pointer is over the vertical lines at the L.F. ends of the bands when the ganged capacitor is at maximum capacitance.

CIRCUITS	NOTES	SERVICE SIG. GEN. SETTING	SERVICE SIG. GEN. TERMIN'TN	CONNECT SIG. GEN. TO	RECEIVER DIAL SETTING	RECEIVER RANGE	ADJUSTMENTS
I.F.	Unscrew 2nd I.F. Pri. and Sec. cores to fullest extent.	465 Kc/s (645 m)	Direct via · 1 μ F	V1 Control Grid	550 m	M.W.	2nd I.F. Pri. (L 19) 2nd I.F. Sec. (L 21) Do not re-adjust
	Unscrew 1st I.F. Pri. and Sec. cores to fullest extent.	465 Kc/s (645 m)	Direct via · 1 μ F	V1 Control Grid	550 m	M.W.	1st I.F. Pri. (L 17) 1st I.F. Sec. (L 18) Do not re-adjust
S.W.	Repeat these adjustments until there is no further improvement.	7.14 mc/s (42 m)	Dummy Aerial	Æ Socket	42 M	S.W.	S.W. Oscillator Coil (L 16) S.W. Grid Coil (L 3)
	L3 is adjusted by moving the wire loop inside the coil, with a non-metallic object, until maximum gain is obtained.	15.25 mc/s (19.7 m)	Dummy Aerial	Æ Socket	19.7 m	S.W.	S.W. Oscillator Trimmer (C 22) S.W. Grid Trimmer (C 2)
M.W.	Repeat these adjustments until there is no further improvement.	600 Kc/s (500 m)	Dummy Aerial	Æ Socket	500 m	M.W.	M.W. Oscillator Coil (L 13) M.W. Grid Coil (L 6)
		1363 Kc/s (220 m)	Dummy Aerial	Æ Socket	220 m	M.W.	M.W. Oscillator Trimmer (C 21) M.W. Grid Trimmer (C 3)
L.W.	Repeat these adjustments until there is no further improvement.	158 Kc/s (1900 m)	Dummy Aerial	Æ Socket	1900 m	L.W.	L.W. Oscillator Coil (L 11) L.W. Grid Coil (L 8)
		300 Kc/s (1000 m)	Dummy Aerial	Æ Socket	1000 m	L.W.	L.W. Oscillator Trimmer (C 16)