

BA228 & B229

BA228 & B229

MURPHY SERVICE INSTRUCTIONS

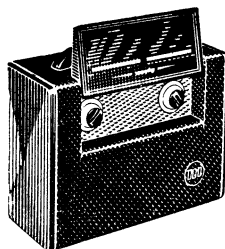

SPECIFICATION

MAINS SUPPLY:	BA228 only:	200-250V a.c., 50-100 c/s
BATTERY SUPPLY:	BA228 and B229:	H.t.: 90V L.t.: 1.5V
CONSUMPTION:	Mains:	7 watts average
	Battery:	L.t.: 225mA H.t.: 10mA (no signal)
WAVE BANDS:	Medium:	187-540 metres
	Long:	1000-2000 metres
INTERMEDIATE FREQUENCY:		470 Kc/s
VALVES:		1C2, 1F1, two 1FD1, two 1P1
SCALE LAMPS:	BA228:	Two 12-14V, 0.75W l.e.s.
LOUDSPEAKER:	Type:	Elliptical 6 in. by 4 in.; permanent magnet
	Impedance:	3 ohms
OVERALL DIMENSIONS:		15½ in. wide, 12½ in. high, 7 in. deep
WEIGHT:	BA228:	13 lb. without batteries
	B229:	11 lb. without batteries
RELEASED:		September, 1954
PRICE:	BA228:	£17 5s. od. plus P.T.
	B229:	£14 16s. 3d. plus P.T.

Issued by

MURPHY RADIO LTD
WELWYN GARDEN CITY · HERTS

Telephone: WELWYN GARDEN 3434

FILAMENT VOLTAGE

BA228 Only

It is most important that, if any of the valves, or components associated with the mains filament supply are changed, the filament line voltage must be checked and, if necessary, adjusted. Use a high resistance d.c. voltmeter (300 ohms/volt or more) and proceed as follows:

1. With the chassis the correct way up, measure the voltage between the chassis (negative) and test point 98 on the MAINS-OFF-BATTERY switch; the voltage should be between 1.3 and 1.4 volts. If the voltage is outside these limits, move the filament voltage adjustment lead (test point 92) on the panel at the top of the mains transformer (T2) to one of the other filament winding tags (test points 87, 88, 89, or 91), to give a voltage as near as possible to 1.35 volts. Switch "Off" and disconnect the mains lead before each adjustment, and **make sure that no contact is made between the filament circuit and the heat fuse.**

2. With the chassis upside down, measure the voltage between the chassis (negative) and test point 97 on the l.t. smoothing choke (L28); the voltage should be between 1.3 and 1.4 volts. If the reading is outside these limits, move the filament voltage adjustment lead (test point 86) on L28 tag panel, to one of the otherappings (test points 93, 94, or 96), to give a voltage as near as possible to 1.35 volts. Switch "Off" before each adjustment and **make sure that no contact is made between the filament circuit and the h.t. tags at one end of L28 tag panel.**

Replacement rectifiers. If, after fitting a replacement l.t. rectifier (M.R.2), the l.t. volts are too high and cannot be corrected by means of the taps on T2 and L28, the resistor R35 (22Ω, 0.6W Part No. 24293) must be fitted. See Figs. 3 and 4.

BATTERY REPLACEMENTS

A combined 90V h.t. and 1.5V l.t. battery is required for these receivers and suitable types are as follows:

Drymax 503
Ever Ready B103
G.E.C. BB503

Siemax S103
Vidor L5507

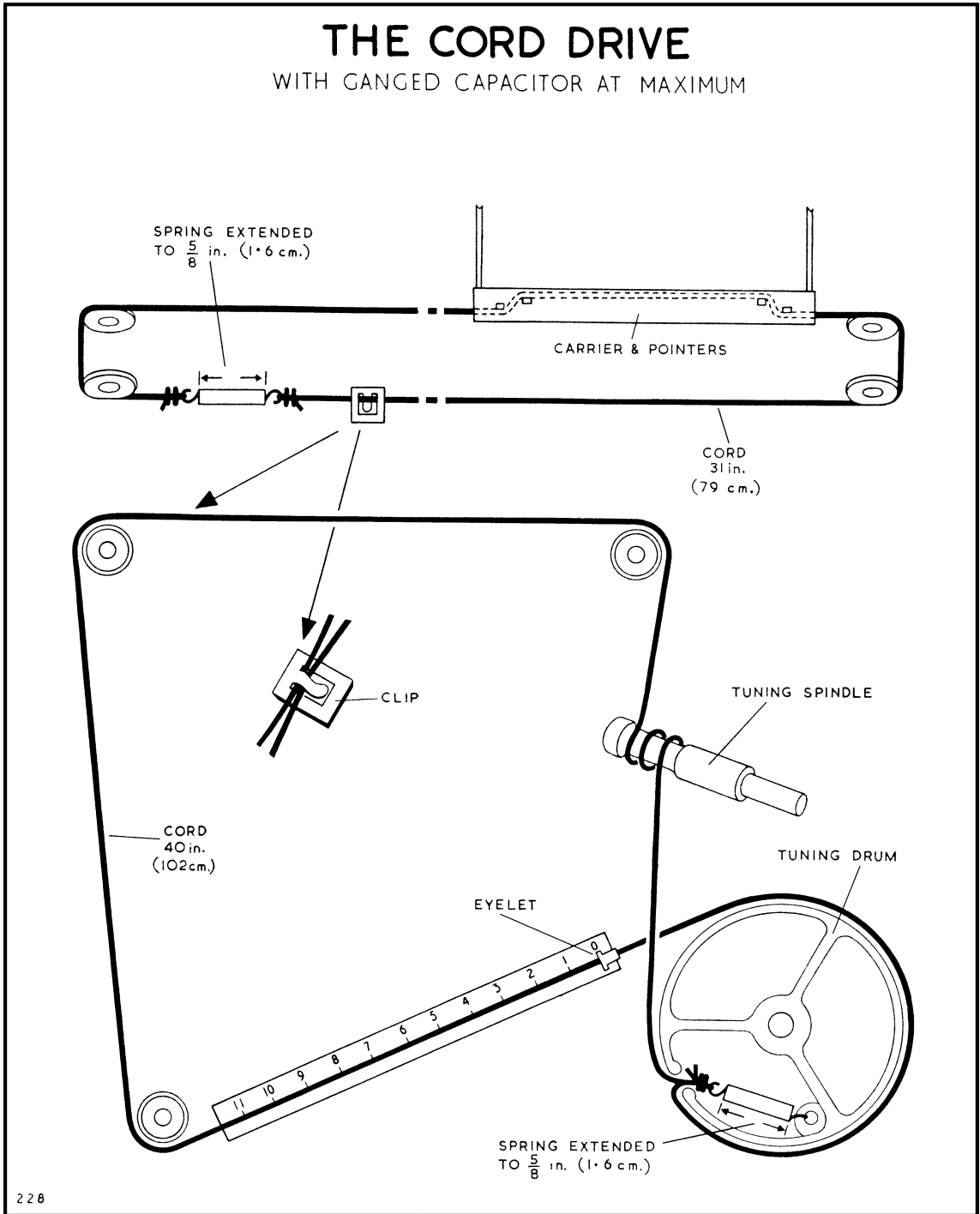

228

Fig. 1

CIRCUIT ALIGNMENT

- 1. Alignment in cabinet.** All trimmers can be adjusted without removing the chassis from the cabinet.
- 2. I.f. transformers.** These are hermetically sealed by means of rubber plugs tightly pressed into the trimmer holes. Remove these plugs to realign the i.f. circuits, but replace them tightly as quickly as possible. *Note: It must be understood that the rubber plugs must not be removed from the i.f. transformer cans unless alignment is proved to be essential.*
- 3. Receiver output.** Make all adjustments for maximum output with the volume control at maximum. Adjust the signal generator attenuator so that this output does not exceed 50mW, or 0.4V across the loudspeaker speech coil.
- 4. Trimming tool.** A non-metallic tool must be used for adjusting the coil cores.
- 5. Coil cores.** These must be adjusted to lie between the middle of the winding and the open end of the coil former in each case.
- 6. Receiver setting.** Each of the dimensions shown in brackets under the heading "Receiver Setting" in the *Circuit Alignment Table* refers to the travel of an eyelet—on the drive cord—along the centimetre scale attached to the front flange of the chassis. See below.
- 7. Tuning pointers.** When the ganged capacitor is at maximum capacitance (this occurs before the stop is reached):
 - (a) the eyelet on the tuning drive cord must register with 0.2 on the scale fixed to the chassis, and
 - (b) when the chassis is in the cabinet, the medium wave pointers must register with the right-hand edge of the 540m. marking on the glass scale; move the pointer drive cord relative to the tuning drive cord if a correction is required.
- 8. R.f. alignment.** The aerial circuits can be aligned only when the chassis is inside the cabinet and the loop aerial is properly connected. To adjust the oscillator circuits when the chassis is outside the cabinet, connect the signal generator to VI pin 6.

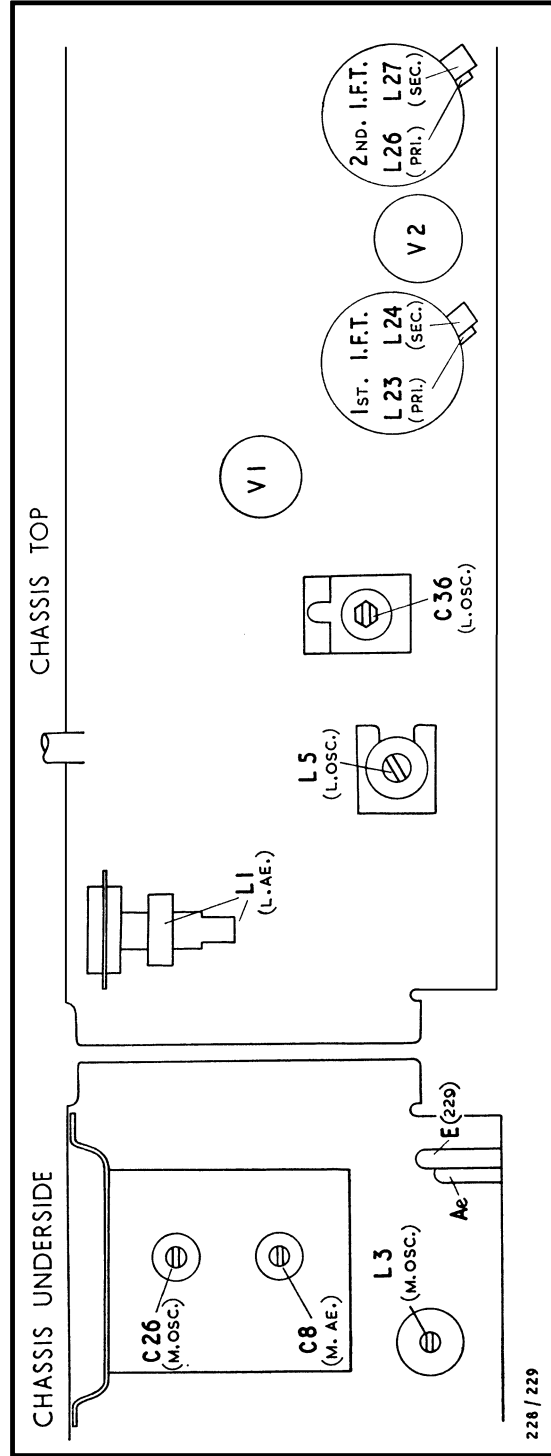

228 / 229

Fig. 2

CIRCUIT ALIGNMENT TABLE

CIRCUIT	NOTES	SIG. GEN. FREQUENCY	SIG. GEN. TERMINATION	CONNECT SIG. GEN. TO	RECEIVER SETTING	ADJUSTMENTS
2nd i.f.t.	Unscrew pri. core (top of can) and both 1st i.f.t. cores before starting adjustments	470 Kc/s	Via 0.01 μ F capacitor	V2 grid 1 (pin 6)	Ganged capacitor at maximum	L27 (sec.) top of can L26 (pri.) bottom of can DO NOT RE-ADJUST SEC. CORE
1st i.f.t.	Switch to M. band	470 Kc/s	As above	V1 grid 3 (pin 6)	As above	L24 (sec.) top of can L23 (pri.) bottom of can DO NOT RE-ADJUST SEC. CORE
Medium	Repeat these adjustments until there is no further improvement	600 Kc/s (500 m.)	Via dummy aerial	Ext. aerial socket	500 m. (2.0 cm.)	L3 (osc.) below chassis
		1500 Kc/s (200 m.)	As above	As above	200 m. (9.6 cm.)	C26 (osc.) below chassis C8 (ac.) below chassis
Long	As above	157.9 Kc/s (1900 m.)	As above	As above	1900 m. (1.95 cm.)	L5 (osc.) above chassis L1 (ac.) above chassis
		300 Kc/s (1000 m.)	As above	As above	1000 m. (9.6 cm.)	C36 (osc.) above chassis

BA228 RECEIVER

C	4	5	10	2	19	8	6	21	35	36	22	32	29	13	25	38	39	42	41	44	43	46	52	48	49	51	54	57	56	58	59	64	62	63	C
R	5			1	4	3		2	7			8	9	13	18	14	16	17	15	23	24	27	26	28	29	34	33	32	31	36	35			R	

BA228

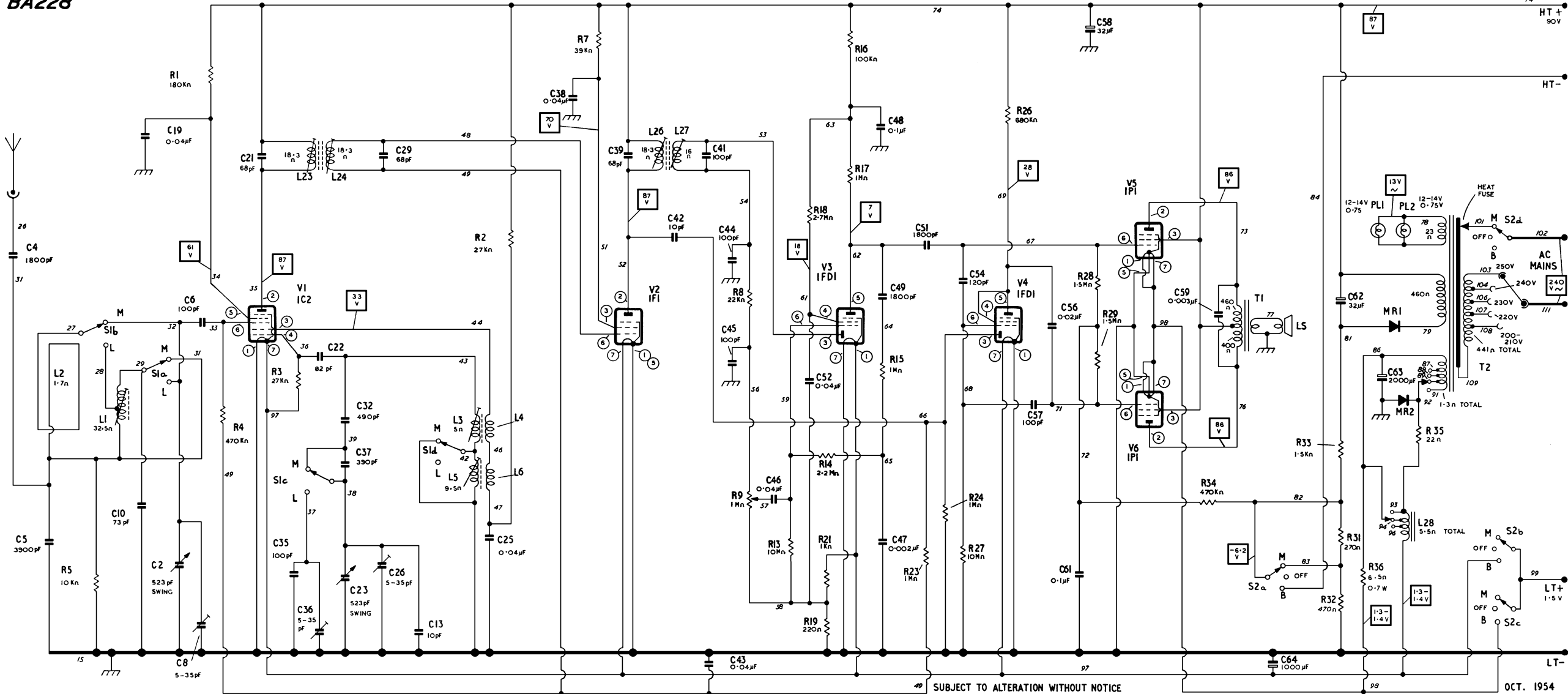

Fig. 3.

Circuit voltages are shown within squares and were measured under no-signal conditions with the receiver switched to the M band, using a 20KΩ/V meter. The BA228 was operating from 240V a.c. mains. Where the resistance of a coil is less than one ohm the value is omitted.

The valve pin numbers are shown within small circles. Component terminals and connecting leads are identified by test point (t.p.) numbers which correspond with those appearing on the chassis diagrams. Alternative valve types are listed on page 12.

B229 RECEIVER

C	5	10	2	19	6	21	35	36	22	32	23	29	13	25	38	39	42	41	44	43	46	52	49	51	54	57	56	58	59	C		
R	5					4	3						2		7				8	9	13	18	14	17	15	23	24	26	30	28	29	R

B229

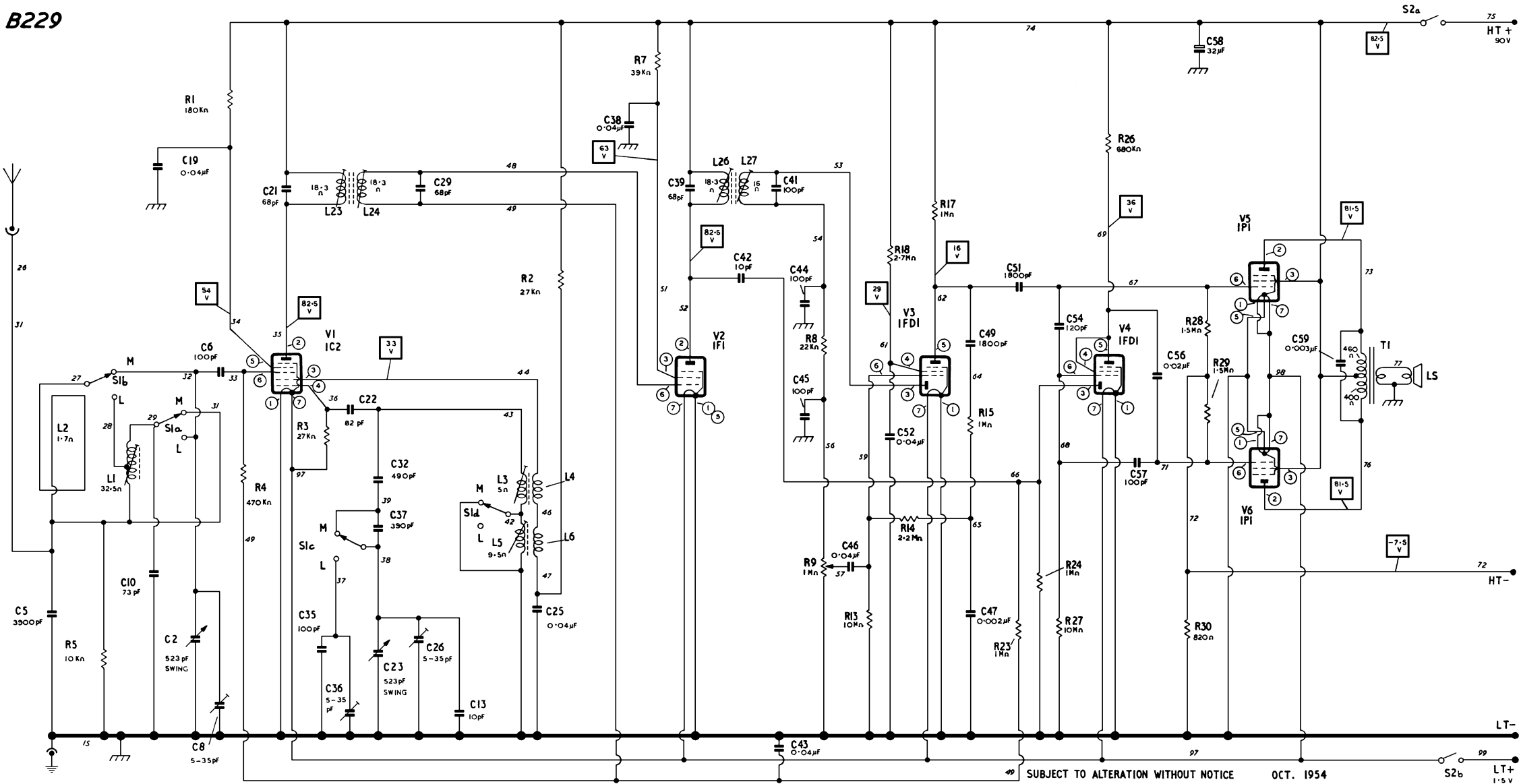

Fig. 3.

Circuit voltages are shown within squares and were measured under no-signal conditions with the receiver switched to the M band, using a 20K Ω /V meter. The B229 was operating from a 1.5V and 90V battery. Where the resistance of a coil is less than one ohm the value is omitted.

The valve pin numbers are shown within small circles.

Component terminals and connecting leads are identified by test point (t.p.) numbers which correspond with those appearing on the chassis diagrams.

Alternative valve types are listed on page 12.

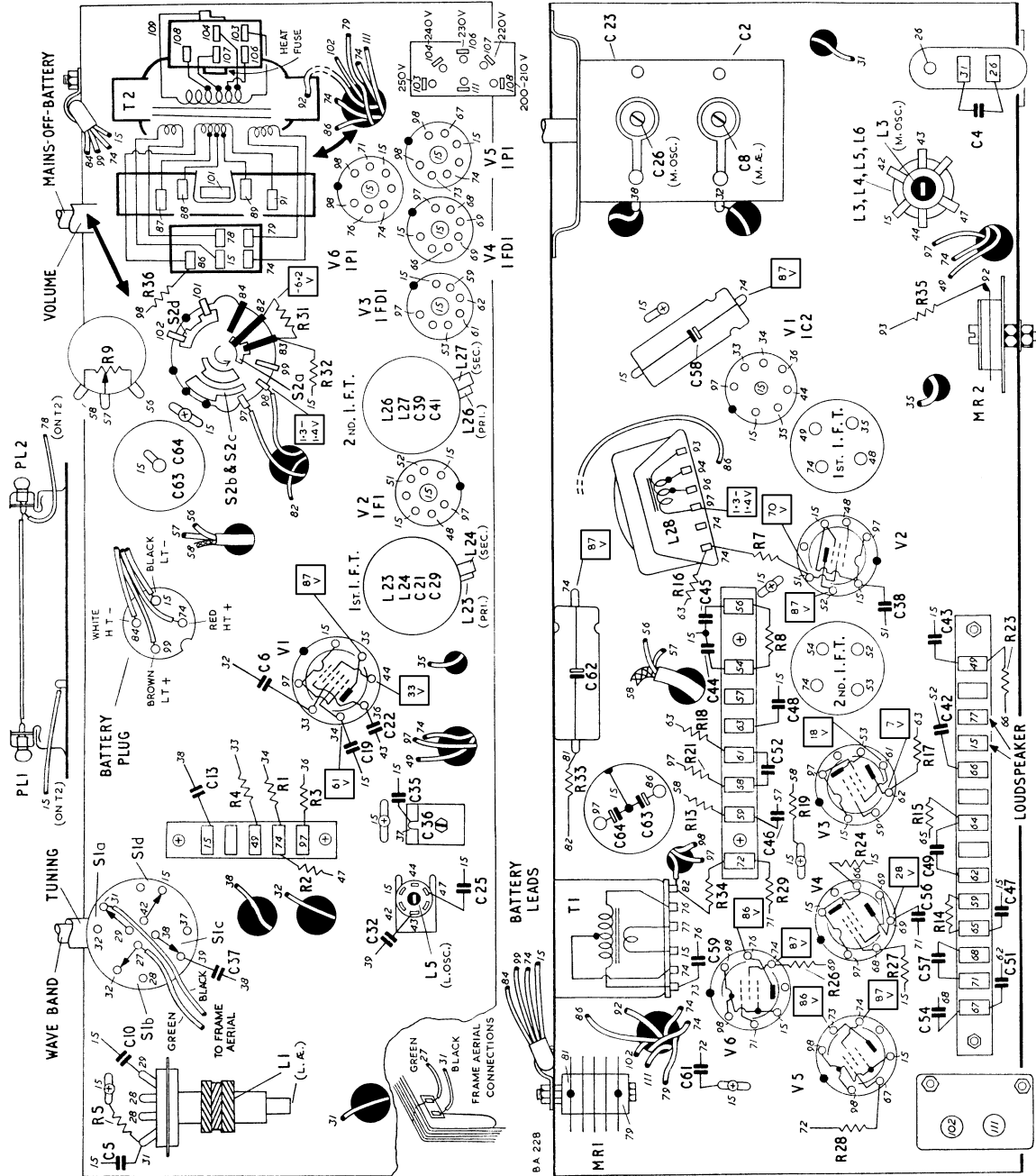

Fig. 4. The top and underside of the BA228 receiver chassis.

B229 RECEIVER

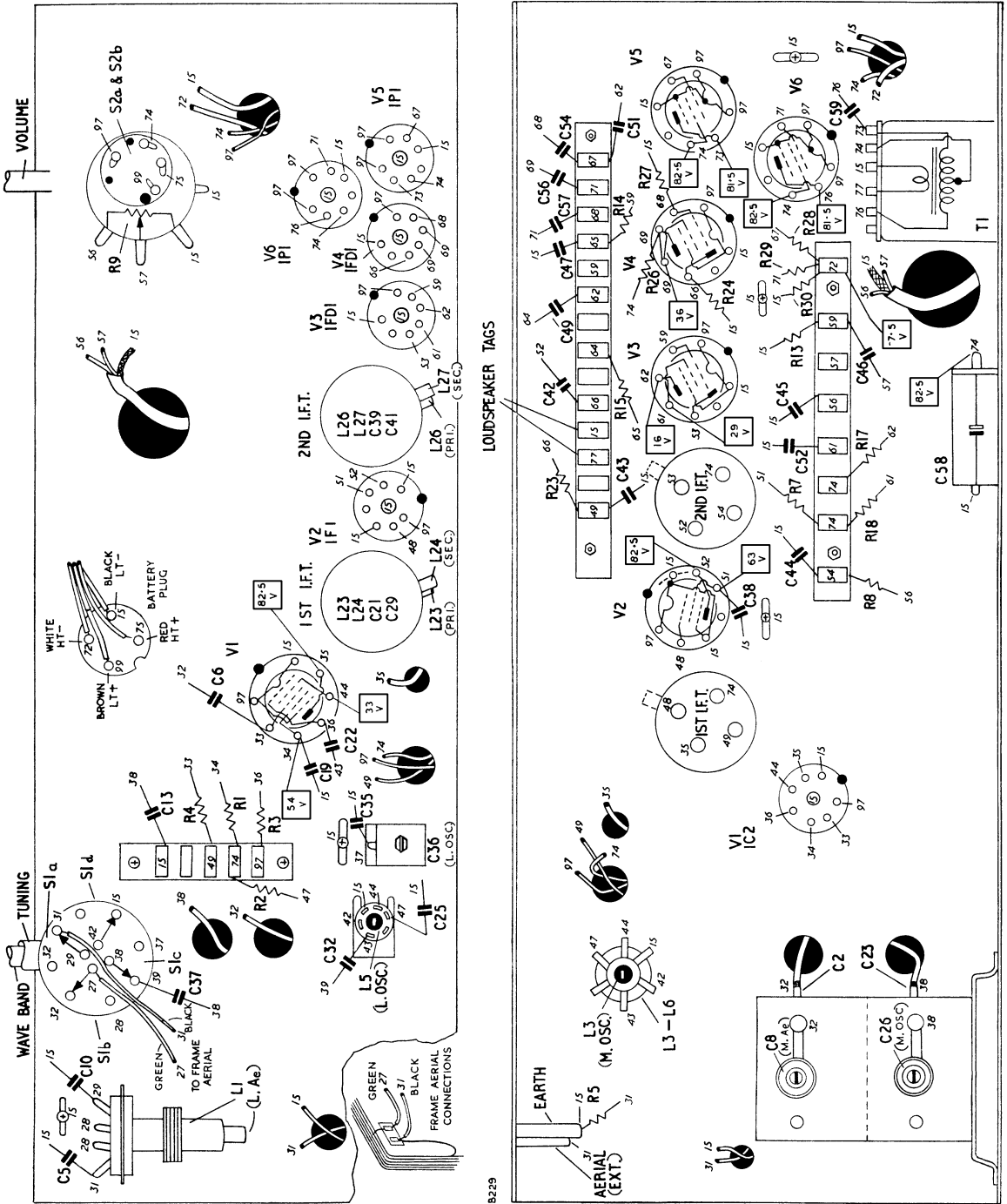

Fig. 5. The top and underside of the B229 receiver chassis.

PARTS LIST (Electrical Components)

The d.c. resistance quoted for the coil and transformer windings is an average figure and should be used as a general guide only; it is omitted where the value is less than one ohm.

The following abbreviations are used in the table below:

p.s.m.	—	protected silvered mica	i.elec.	—	insulated electrolytic
cer.	—	ceramic	V d.c.	—	d.c. voltage rating
tub.	—	paper tubular	V a.c.	—	a.c. voltage rating
m.tub.	—	metallized paper tubular	W	—	wattage rating
i.s.tub.	—	insulated sealed paper tubular (metal cased)	w.w.	—	wire wound
elec.	—	electrolytic	log.	—	logarithmic law
			inv. log.	—	inverse logarithmic law

PART NO.	CIRCUIT NO.	VALUE	TOLERANCE AND REMARKS	PART NO.	CIRCUIT NO.	VALUE	TOLERANCE AND REMARKS		
52302	C2	523 pF (swing)	Ganged capacitor, ae. section (with C23)	41404	C61	0.1 μ F	20%, tub., 350V d.c. (228)		
60822	C4	1800 pF	+80% -20%, cer., 1250V d.c. (228)	56163	C62	32 μ F	+100% -20%, i.elec., 150V d.c. (228)		
28249	C5	3900 pF	5%, p.s.m., 350V d.c.	56164	C63	2000 μ F	+100% -20%, elec., 6V d.c.		
54070	C6	100 pF	20%, cer., 500V d.c.				C64	1000 μ F	+100% -20%, elec., 6V d.c. (228)
52302	C8	5-35 pF	Trimmer, M. ae. (with C2)						
28370	C10	73 pF	2%, p.s.m., 350V d.c.	25797	R1	180 K Ω	10%, 0.6W		
23601	C13	10 pF	10%, p.s.m., 350V d.c.	25477	R2	27 K Ω	10%, 0.6W		
49454	C19	0.04 μ F	25%, m.tub., 150V d.c.	25477	R3	27 K Ω	10%, 0.6W		
52635	C21	68 pF	5%, p.s.m., 350V d.c.	27397	R4	470 K Ω	20%, 0.6W		
54069	C22	82 pF	20%, cer., 500V d.c.	27077	R5	10 K Ω	20%, 0.6W		
52302	C23	523 pF (swing)	Ganged capacitor, osc. section (with C2)	25541	R7	39 K Ω	10%, 0.6W		
49454	C25	0.04 μ F	25%, m.tub., 150V d.c.	27141	R8	22 K Ω	20%, 0.6W		
52302	C26	5-35 pF	Trimmer, M. osc. (with C23)	52850	R9	1 M Ω	Volume control, inv. log (228)		
52635	C29	68 pF	5%, p.s.m., 350V d.c.	52801	R9	1 M Ω	Volume control, log. (229)		
28369	C32	490 pF	1%, p.s.m., 350V d.c.	27653	R13	10 M Ω	20%, 0.6W		
28156	C35	100 pF	5%, p.s.m., 350V d.c.	26213	R14	2.2 M Ω	10%, 0.6W		
56323	C36	5-35 pF	Trimmer, L osc.	26085	R15	1 M Ω	10%, 0.6W		
28311	C37	390 pF	1%, p.s.m., 350V d.c.	27269	R16	100 K Ω	20%, 0.6W (228)		
49454	C38	0.04 μ F	25%, m.tub., 150V d.c.	27461	R17	1 M Ω	20%, 0.6W		
52635	C39	68 pF	5%, p.s.m., 350V d.c.	26245	R18	2.7 M Ω	10%, 0.6W		
52630	C41	100 pF	5%, p.s.m., 350V d.c.	24677	R19	220 Ω	10%, 0.6W (228)		
54058	C42	10 pF	20%, cer., 750V d.c.	24933	R21	1 K Ω	10%, 0.6W (228)		
49459	C43	0.04 μ F	25%, m.tub., 150V d.c.	27461	R23	1 M Ω	20%, 0.6W		
52952	C44	100 pF	20%, p.s.m., 350V d.c.	27461	R24	1 M Ω	20%, 0.6W		
49454	C45	100 pF	20%, p.s.m., 350V d.c.	27429	R26	680 K Ω	20%, 0.6W		
49454	C46	0.04 μ F	25%, m.tub., 150V d.c.	27653	R27	10 M Ω	20%, 0.6W		
49452	C47	0.002 μ F	10%, m.tub., 350V d.c.	27493	R28	1.5 M Ω	20%, 0.6W		
41404	C48	0.1 μ F	20%, tub., 350V d.c. (228)	27493	R29	1.5 M Ω	20%, 0.6W		
54090	C49	1800 pF	20%, cer., 500V d.c.	24901	R30	820 Ω	10%, 0.6W (229)		
54090	C51	1800 pF	20%, cer., 500V d.c.	24709	R31	270 Ω	10%, 0.6W (228)		
49454	C52	0.04 μ F	25%, m.tub., 150V d.c.	24805	R32	470 Ω	10%, 0.6W (228)		
28276	C54	120 pF	5%, p.s.m., 350V d.c.	26917	R33	1.5 K Ω	20%, 0.6W (228)		
53066	C56	0.02 μ F	20%, i.s.tub., 350V d.c.	27397	R34	470 K Ω	20%, 0.6W (228)		
52630	C57	100 pF	5%, p.s.m., 350V d.c.	24293	R35	22 Ω	10%, 0.6W (228)		
56150	C58	32 μ F	+100% -20%, elec., 150V d.c.	63927	R36	6.5 Ω	5%, 0.7W w.w. (228)		
57790	C59	0.003 μ F	25%, m.tub., 300V d.c.						

PART NO.	CIRCUIT NO.	RESISTANCE (D.C.)	REMARKS	PART NO.	CIRCUIT NO.	RESISTANCE (D.C.)	REMARKS		
64470	L1	32.5 Ω	L ae.	63928	L28	5.5 Ω total	L.t. choke (228)		
67659	L2	1.7 Ω	M frame ae.						
64471	L3	5 Ω	Tuned	62881	T1	460+400 Ω	Pri. Sec. } o.t.		
	L4	—	Coupling						
	L5	9.5 Ω	Tuned						
	L6	—	Coupling						
63932	L23	18.3 Ω	Pri. } 1st i.f.t.	64856	T2	441 Ω total	Pri. H.t. sec. } M.t. (228)		
	L24	18.3 Ω	Sec. }						
63933	L26	18.3 Ω	Pri. } 2nd i.f.t.					23 Ω	L.t. sec. }
	L27	16.0 Ω	Sec. }						

PARTS LIST (Mechanical Components)

This list contains only those parts which are not included in the Electrical Parts List; items such as self-tapping screws, bolts, and nuts, etc., may be obtained from Murphy Radio Ltd, Service Department. Where more than one item is used in each receiver, the quantity is given in brackets after the description.

PART NO.	DESCRIPTION	REMARKS	PART NO.	DESCRIPTION	REMARKS
67659	Aerial	frame	1871/2	Compound	for coil cores
64614	Back for cabinet	complete	64836	Connector, mains	mains lead with moulded socket (228)
64103	Bracket and pulley (2)	for chassis (228)	2025/10	Cord	for top of cabinet back
64104	Bracket and pulleys	for tuning scale frame and pointer cord	3962/1	Cord	for tuning drives
64755	Bracket, fastening (2)	for cabinet back	46913	Core, iron dust (2)	for L3 and L5
63854	Bracket, mounting (2)	for chassis in cabinet	46910	Core, iron dust	for L1
64468	Bracket, mounting	for ganged capacitor	64857	Cover	for chassis underside (228)
64469	Bracket, mounting	for L ae. coil	64467	Cover	for chassis underside (229)
63888	Bracket, mounting	for Volume control and Mains - Off - Battery switch (228)	64544	Coupling, sleeve	for linking volume control knobs
63886	Bracket, mounting (2)	for Volume control, tuning and wave change switch (229)	48189	Drum, tuning	for ganged capacitor
63886	Bracket, mounting	for tuning and wave change switch (228)	63850	End, moulded (2)	for cabinet
63865	Bush, felt (4)	for tuning pointers	15628	Eyelet	for tuning drive cord
65651	Cabinet assembled, with cord drive and frame aerial	less lampholders and fitting, tuning scale and pointers	15633	Eyelet (6)	inside grommets (42844)
63877	Circlip	for volume and tuning spindles	3673/8	Felt, ½ in. adhesive	between loudspeaker baffle and grille
14347	Clamp (2)	for battery lead	63170	Foot (4)	for cabinet
14337	Clamp ¾ in.	for C58 and C62	64125	Frame	for tuning scale
34183	Clamp 1 in.	for C63 and C64 (228)	0075/1	Fusible alloy	for heat fuse (228)
64473	Clip (2)	for switch knobs	63878	Gear wheel, driving	for volume control (228)
52292	Clip, fastening (2)	for aerial and osc. coil	63879	Gear wheel, driven	for volume control (228)
63887	Clip, retaining (2)	for i.f. cans	65250	Grille and escutcheons	for loudspeaker and knobs (228)
37973	Clip, spring	for loudspeaker leads	64804	Grille and escutcheons	for loudspeaker and knobs (229)
63866	Clip, spring	for linking tuning drive cords	65412	Grip (2)	fastening for ends of cord loop on cabinet back
64013	Clip, spring (12)	for fastening cabinet ends and pivot bush (63858)			
64754	Clip, spring (2)	for fastening cabinet back			

PART NO.	DESCRIPTION	REMARKS	PART NO.	DESCRIPTION	REMARKS
42844	Grommet (6)	inside rear bottom corners of cabinet and for mounting V1 and V3 holders	64447 64129 58850	Plug, rubber (4) Pointers and carrier Pulley (7)	for i.f. transformers for tuning scale for cord drives
63851	Handle	for cabinet	55235	Rectifier, h.t.	Westinghouse type 15C997 (228)
63872	Knob, large (2)	for volume and tuning for switches	55234	Rectifier, l.t.	Westinghouse type 01L999 (228)
67660	Knob, small (2)		63881	Scale, calibration	on chassis front
59397	Label, warning	“Heat Fuse” (228)	64476	Scale, tuning	on cabinet
64392	Label, warning (2)	for i.f. transformers	103504	Screw, 4BA $\frac{1}{4}$ in. (2)	for chassis fixing
63980	Lamp (2)	12-14V, 0.75W, l.e.s. (228)	62600	Screw, 6BA $\frac{3}{8}$ in. tropical finished brass (2)	for fastening tuning scale
64462	Lampholder (2)	(228)	14711	Spacer (2)	for tag strip below chassis
61015	Loudspeaker	6 in. by 4 in., elliptical	63876	Spindle, tuning	for cord on cabinet back for cord drives
64165	Pad, ring	for loudspeaker	19474	Spring	
64459	Panel and plugs	for mains supply connection (on chassis) (228)	47478	Spring (2)	for lamp holders (228)
65797	Panel, external aerial	with socket and tags (228)	63860	Spring, mounting	for gear wheel (63879) (228)
65249	Panel, mains adjustment	with tags and bracket (228)	63476	Spring, retaining	for tuning scale frame
68228	Panel, earth and external aerial	with sockets and tags (229)	64924	Stop	Mains - Off - Battery (228)
55695	Pin (7)	rivet for pulleys	63889	Switch	Wave band
63858	Pivot bush (2)	for tuning scale frame	64474	Switch	
64127	Plate (2)	between ends of handle and cabinet	629998	Tag, Ross Courtney	cleats for scale lamp leads (228)
64835	Plug (2)	for holes at left-hand side of cabinet back	64126	Trim (2)	ornamental wire for cabinet ends
47351	Plug, 2 pin	for mains adjustment (228)	56217	Valve holder (5)	B7G
64832	Plug, black	for external aerial (228)	62529	Valve holder	B7G for V1
64832	Plug, black	for earth lead (229)	16649	Washer, shakeproof, $\frac{3}{8}$ in.	for fixing controls
64831	Plug, red	for external aerial (229)			
62314	Plug, British, 4 pin	for battery			

ALTERNATIVE VALVES

V1 — DK92

V3 and V4 — DAF96

V2 — DF96

V5 and V6 — DL96

REMOVING THE CHASSIS

Remove both pairs of pull-off knobs. If these are too tight to be easily pulled with the fingers, they may be eased off by passing a loop of string between them and the speaker grille, and then giving a straight pull.

Detach the drive cord on the chassis from the spring clip, leaving the clip on the cord in the cabinet.

Unsolder the frame aerial connections from the tags on the left-hand side of the cabinet (when looking in back).

Unsolder the pilot lamp connections (BA228 only) from the tags on the right-hand side of the cabinet (when looking in back).

Remove the cover from the chassis underside and disconnect the loudspeaker leads from the tag strip on the rear of the chassis.

Remove the chassis fixing screws and withdraw the chassis.